

Snark Sailboat Manual

Mach II or Jetwind

(Discontinued – No Parts Are Available)

This manual provided as a courtesy from:

CastleCraft

www.castlecraft.com

815-458-3590

888-274-8490

MACH II

OWNERS MANUAL



SNARK PRODUCTS INC.
ONE RIVERSIDE PLAZA
NORTH BERGEN, N. J. 07047

MACH II SPECIFICATIONS

Your Mach II has sufficient built in foam flotation to exceed the recommendations of the Boating Industry Association for the load stated on the Capacity Plate.

Your boat is made of Corlite, an expanded polystyrene/thermoplastic sandwich construction. It is light, strong, weather resistant and water tight. With proper care and handling, your boat should provide years of trouble-free service.

Length	- of hull	13'-10-1/8"
Length	- Overall	13'-11 1/4"
Length	- Gunwale (CL to CL)	15-10-3/8"
Beam	- Maximum	49-11/16"
Depth	- Midships	13-3/16"
Draft	- Board up	4"
Draft	- Board down	33 1/4"
Transom	- Beam	31-11/16"
Transom	- Height	7"
Weight	- Hull (less board, rudder, rig)	..	90 lb.
Weight	- Complete	125 lbs.
Sail Area	-	82 sq. feet
Load Capacity	-	500 lbs.
Passengers	- (at 150# each - or equivalent).		3
Overall Height	-		17' 9"

TRANSPORTING

Transporting any boat on a cartop rack or trailer places considerable stress on the hull unless properly supported. Care must be used in adjusting straps, cables and clamps to prevent excessive pressure on the boat.

In cartopping, the boat should rest inverted on its gunwales. Padding should be placed between the gunwales and the cartop carrier to prevent chaffing. In addition to securing the boat to the cartop carrier, the bow and stern should be secured to the vehicle to prevent longitudinal movement.

Trailer supports must be adjusted so they contact the hull uniformly. Longitudinal supports should be contoured to exactly fit the hull bottom. Forward and midship keel supports should be of the "BUNK" type. DO NOT support the keel on rollers only as full distortion may occur.

Loose gear must be removed from the boat before trailering. At highway speeds, loose gear can blow out of the boat and cause serious damage and injury to following vehicles.

YOUR MACH II GUARANTEE

Your boat is warranted against defective workmanship and materials for a period of ninety days after purchase. Parts found to be defective as a result of faulty work-

manship or materials will be replaced by us without charge.

MACH II ASSEMBLY & RIGGING INSTRUCTIONS

Before assembling and rigging your new Mach II, be sure to read the Owners Manual thoroughly - become intimately familiar with the nomenclature of each of the parts - and their function.

First, unpack all parts, identify them, and check with the material list and be sure that all parts have been accounted for.

RUDDER / TILLER ASSEMBLY

Attach hiking stick swivel assembly (Part # 319) to top of tiller (Part # 1657) with two screws (Part # 320) in predrilled holes. Attach hiking stick (Part # 1658) to swivel assembly with bolt (Part # 323) and self-locking nut. Assemble rudder by placing round ethafoam friction disc (Part # 312) between rudder head casting (Part # 1636) and blade (Part # 1633), passing pivot bolt (Part # 1634) through casting, pad, blade and bearing washer, and securing with self-locking nut.

NOTE: The ethafoam disc allows correct friction to be maintained on the pivoting rudder blade. Adjust the torque on the rudder pivot bolt so that a 5 pound load at the base of the rudder blade will swing the blade up.

Remove the nut and flat washer from the tiller bolt located at the wide end of the tiller (Part # 1657). Back the bolt out until it clears the slot in the tiller. Place the tiller on the rudder head casting (Part # 1636) and reinstall the bolt, washer and nut, and tighten. Make sure the hiking stick (Part # 1658) is on the top side of the tiller.

Remove the safety pin (Part # 1659) from the lower end of the rudder "L" pin (Part # 1637) and remove the "L" pin from the gudgeon plate (Part # 1639). Position the rudder head casting on the gudgeon plate and insert the rudder "L" pin thru holes in casting and gudgeon plate. (See Detail "E") **SECURE SAFETY PIN IN HOLE IN LOWER END OF "L" PIN. THIS WILL PREVENT LOSS OF "L" PIN AND RUDDER ASSEMBLY IF BOAT IS INVERTED.**

Thread one end of the sheet (Part # 504) thru the hole near the aft end of the tiller. Allow the end to project several inches below the tiller - then tie a tight figure eight knot in the end of the sheet. Pull the sheet upward until the knot is firmly against the tiller. Coil the remainder of the sheet and place it in the boat.

ASSEMBLING THE SAIL RIG

You will notice the boom (Part # 512) and the yard (Part # 509) have been connected with a double-eye-bolt. (See Detail "B"). Spread the spars out on a lawn or beach or other clean area so that the yard is to your right and makes a 65-degree angle with the boom (the boom is easily identified by the two blocks and gooseneck (Part # 503) that are attached). Be sure large ring on gooseneck is above boom. Insert the upper yard section (Part # 510) in the lower yard - Be sure the eye in the end cap is pointing towards the boom.

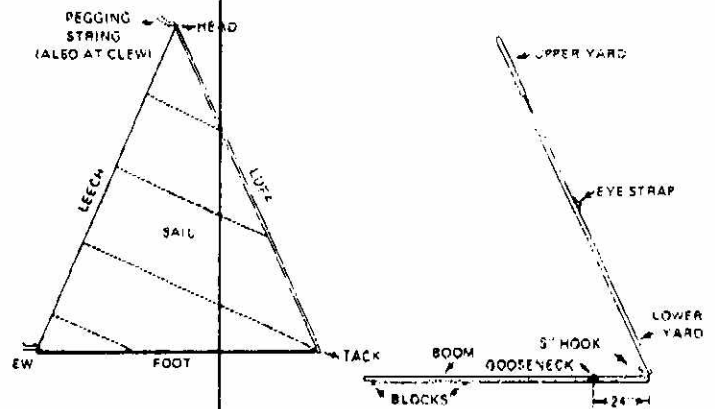

Now lay the sail (Part # 1700) out so that the foot of the sail is next to the boom, and the luff is next to the yard. (This is the only way the sail will fit the spars). Connect the grommet at the tack (lower right hand corner) to the S-hook (Part # 509) that is attached to the double eyebolt. Then tie the pegging string, connected to the clew, to the eye in the end of the boom. (Left hand corner of the sail). Tie the head (upper corner) of the sail to the upper end of the yard. (See Sketch).

For light winds, adjust the pegging strings so that the sail is loose; for higher winds, the foot and luff of the sail should be tighter.

Secure the sail to the spars using 11 nylon rings (Part # 505) on the boom, and 14 on the yard. When installing sail rings DO NOT snap them into place; spread the ends and carefully slip them over the aluminum tubing. Now gently guide the ends of the rings into a relaxed position.

DO NOT allow them to snap into place as damage may occur to the lock pin. Place the male lock pin through the grommet on the sail and press the ends of the sail ring together until the pin locks into hole.

The HALYARD (Part #504) is a 1/4" dacron line used for hoisting the sail on the mast. Secure the halyard to the yard thru the strap eye. DO NOT SECURE THE HALYARD TO THE STRAP EYE ONLY. It must be wrapped around the yard as shown below. The purpose of the strap is to properly locate the halyard on the yard and to prevent the yard from slipping thru the halyard. (See Detail "A").

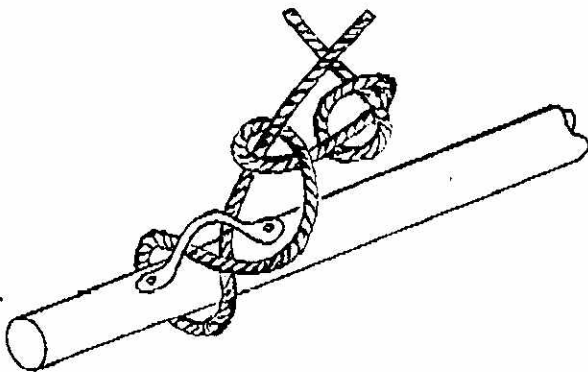

Now slide the lower end of the mast (end with flat cap thru the large ring on gooseneck until the mast head is close to the point on the yard where the halyard is secured. Pass the free end of the halyard thru the mast head fairlead.

You are now ready to rig your Mach II.

RIGGING

Lay the spars (and sail) on the Mach II so that the gooseneck is pointing to the starboard (right side) and directly above the mast step in the deck.

With the mast engaging the gooseneck, raise mast head and insert the foot of the mast in the mast step. Be sure mast completely penetrates the step, and that the lower point of the black arrow on the mast touches the deck. Pass the free end of the halyard thru the block and to the cleat located on the splash rail.

NOTE: It is possible for stones of sand or other foreign objects to accumulate in the bottom of the mast step and prevent the mast fully penetrating the step. This can cause the mast or the mast step to fail under even moderate sailing conditions. It is a good practice to always check the mast step before stepping the mast to be sure that there is no foreign matter in the step. Each time you step the mast, make it a habit to check the black arrow on the aft side of the mast to be sure that it touches the deck. This insures proper engagement between the mast and the mast step.

With boat facing into wind, raise sail by pulling down on halyard until the yard is touching the mast head. Hold the yard in this position and pull the free end of the halyard until it is tight. Secure the halyard to the cleat.

Run the free end of sheet (that's the line you secured to the tiller—thru the aft bullet block and then forward thru the mid-boom bullet block. (See Detail "C")) Tie figure 8 knot in the end of sheet to prevent it from inadvertently running out the bullet blocks. The free end of the sheet is held by skipper when sailing— coil it so it will be handy.

Slide the dagger board (Part #1625) into the dagger board trunk (Part #24).

NOTE: When sailing your boat in shallow water or launching or beaching your boat in shallow water raise the daggerboard to prevent grounding and possible damage to the Daggerboard trunk.

You are now ready to sail!!

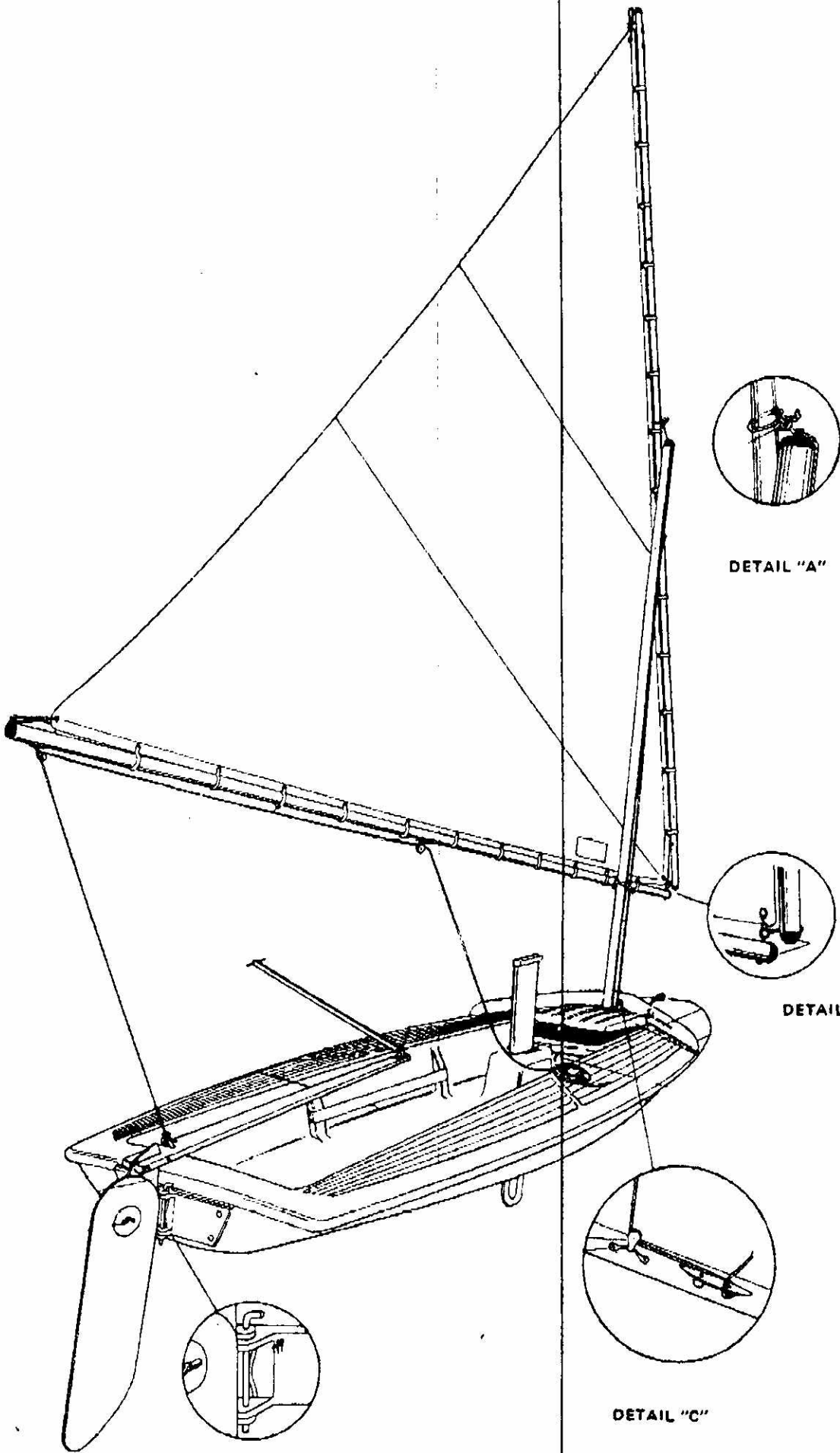

DETAIL "A"

DETAIL "B"

DETAIL "C"

DETAIL "E"

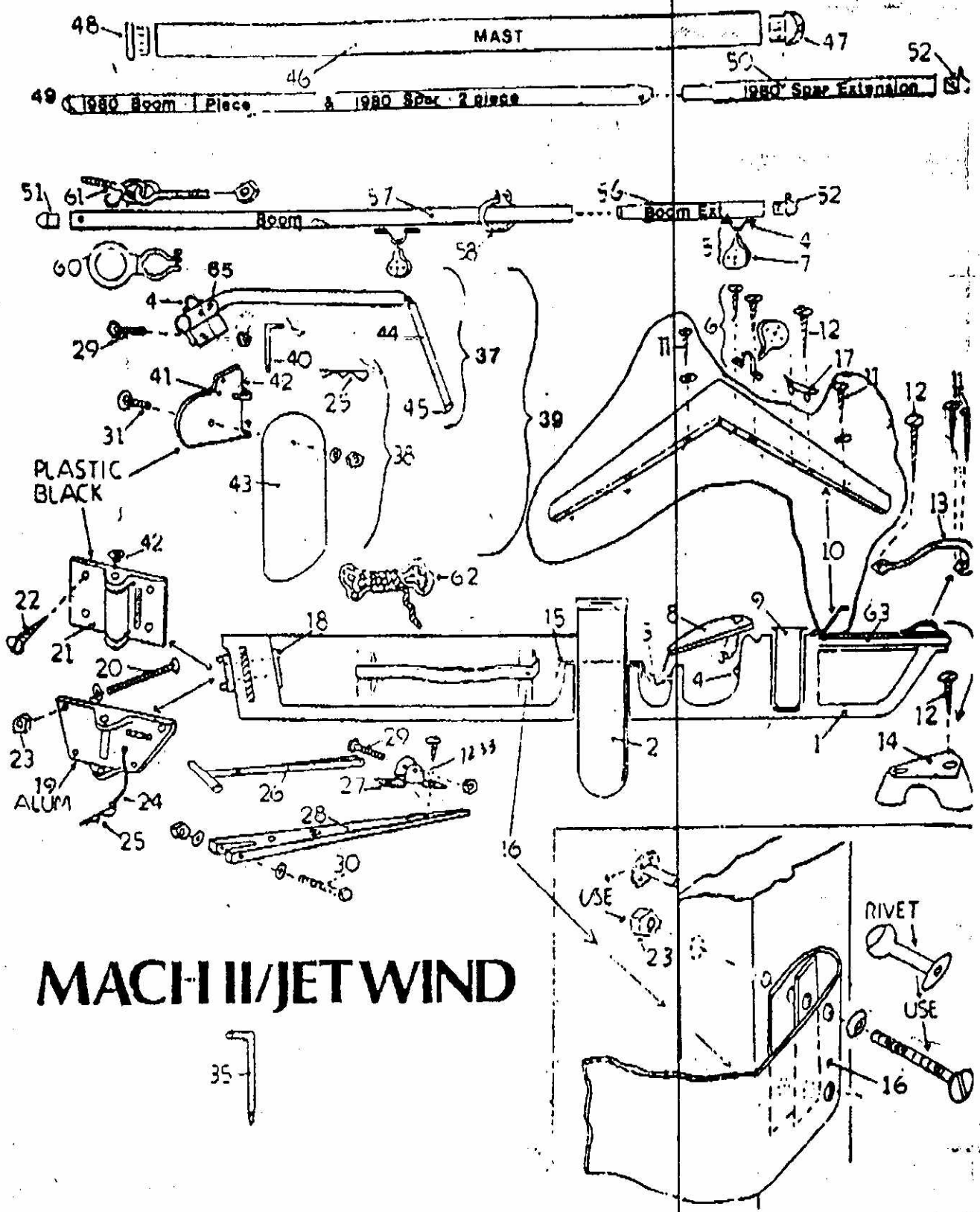

MACH II/JETWIND

Replacement Parts Price List

Items with (*) Asterisk must be shipped by common carrier "Freight Collect" due to the size of item. Items not shipped by common carrier, will be shipped "Prepaid."

Part #	Description	Suggested Retail
61570	1626 Daggerboard	50.00
61000	0904 Eyestrap, White Nylon	.65
60840	0829 Eyestrap, Metal	1.00
75140	7514 Eyestrap w/Pulley Block	4.00
72210	7221 Eyestrap w/Pulley Block & Screws	4.95
60830	0828 Pulley Block only	2.95
72190	7219 Hatch Cover, Complete	39.00
61510	1610 Mast Sleeve	8.95
72180	7218 Splash Roll/Hardware	39.00
61490	1614 #10 Screw, 2 1/2"	1.00
62360	0903 #10 Screw, 3"	1.50
72170	7217 Bow Handle w/Screws	10.00
72510	7251 Bow Eye w/Screws	8.35
61560	1624 Nolleap for Daggerboard	6.95
72200	7220 Cleat w/Screws	5.00
70100	7129 Gudgeon, Aluminum	10.00
70180	1654 #10 Bolt 5 1/2" Nut	1.75
71290	7129 Outer Gudgeon, Plastic w/Screws ('78 & later)	16.00
61010	0913 Locknut 10-32	2.00
72350	7235 Chain & Cotter Pin	3.20
60060	0318 Cotter Pin	1.00
72320	Hiking Stick	10.00
72330	7233 Swivel w/Screws	12.00
70110	Wood Tiller	12.00
70120	0323 #10 Bolt 10 x 1" & Nut	1.75
70130	0324 Bolt 1/2 x 3" w/Nut & Washers	2.00
71300	7130 Bolt, Washer & Nut for Rudder	4.75
70150	1637 "L" Pin, '77 & Prior	14.00
72670	7267 Rudder Assembly only '78 & later, Plastic	59.00
72680	7269 Rudder Assembly Alum w/Blade & Hardware	50.00
62340	1692 "L" Pin - '78 & later	4.00
62020	1820 Rudder Head, Black Plastic	15.00 10.00
70330	Rudder Head, Aluminum	27.00
61850	1691 Rudder Blade	34.00
62470	1674 Cap for Hiking Stick	2.50
72370	*7297 Mast, Complete	00.00
60600	0703 Cap for Mast Head	9.40
60610	0704 Cap for Mast Foot	9.40
70160	* Boom (1 Pc./1980)w/Pulleys	49.00
70161	* Spar-1980	49.00
70170	Spar Extension-1980	25.90
60650	0711 Boom Cap, Plain	2.95
60660	0712 Boom Cap, w/Fairlead	2.95
60410	*0523 Spar, w/Cap 130"	49.00
60420	0524 Spar Extension, 60"	25.90
60430	0525 Boom Extension, w/Pulley, 22"	15.00
60410	*0523 Boom, w/Pulley, 130"	49.00
60340	0505 Sail Rings; (Bag of 27)	15.00
61880	1700 Sail, 82 sq. ft. "Mach II"	175.00
60330	0503 Gooseneck	30.00
72280	7228 Jointed Eyebolts w/Nuts & "S" Hook	12.00
60380	0504 Line, Main Sheet & Halyard	20.00
61460	1610 Dumper	20.00
60360	0508 "S" Hook	1.00
72390	COMPLETE Sail Assembly	399.00

MACH II PARTS LIST

Part No.	Description	Quantity
312	Ethafoam rudder friction pad	1
316	Rudder pivot nut, 5/16 hex lock, SS	1
318	Cotter pin, 1 1/8"	1
319	Hiking stick swivel assembly	1
320	#10 x 1/2" self threading screw, SS	2
323	#10 x 1" hex machine screw, SS	1
324	1/4" -20x3" hex machine screw for part 1657	1
325	1/4" flat washer, SS	1
326	1/4" -20 self locking nut, SS	1
331	Cleat	1
503	Gooseneck	1
504	Sheet/Halyard, 1/4" x 24', dacron	2
505	Sail rings (set of 27)	1 set
508	Jointed eyebolt set, 10x 1 3/4-5/16	1
508	"S" Hook, 3/32" x 3/4", SS	2
509	*Lower yard	1
510	*Upper yard	1
511	*Mast	1
512	*Boom	1
703	Masthead cap	1
704	Mast foot cap	1
707	Bullet block straps	2
708	Swivel bullets blocks	2
709	Eyestraps	4
711	Dome end cap	2
712	Dome end cap w/eye	2
903	#10 OH self threading screw, 3"	3
904	Eyestraps	1
911	Velcro fastener, male	1
912	Velcro fastener, female	1
913	#10 hex nut, self locking, SS	7
926	#10 finish washers for parts 1614, 1639, 1616	18
1600	*Hull	1
1613	Bow handle	1
1614	Self threading screw, OH, 10x2 1/4"	12
1616	Splash rail	1
1620	Hatch cover	1
1621	Shock cord, 5/16" x 8", w/clinch ring	1
1624	Daggerboard trunk cap	1
1626	Daggerboard	1
1628	Hiking strap	2
1633	Rudder blade	1
1634	Rudder pivot bolt	1
1635	5/16" flat washer for pivot bolt	1
1636	Rudder head casting	1
1637	Rudder "L" pin	1
1638	"L" pin retainer chain	1
1639	Gudgeon plate	1
1640	Inner transom plate	1
1647	Hasp for hatch cover closure	1
1654	Transom pad screws	4
1657	Tiller	1
1658	Hiking stick	1
1659	"L" pin retainer chain coupling	2
1661	1/8" flat washer, SS	2
1663	Bullet block	1
1700	Sail	1

NOTE: Make certain you multiply units required by price of each in computing total cost of your order. Prices above are for one piece per item, except where indicated for a pair or set. Enclose your check for the total, plus \$1.00 handling charge. Small items shipped via parcel post prepaid. Add \$8.50 for large items (indicated by asterisk) shipped Railway Express prepaid.

Dear Snark, Sail Department:

I have a 1960's 12' model Mach 2 day sailer. It looks very much like your Snark. My sails are in bad condition. I am interested in replacing the sails. I think maybe your sails will fit. My fax number is (717) 898 - 4990.

Please look at the dimensions below and let me know if you are able to fax me a quote on replacement sails. This is a recreational boat and not a race boat, so plain white durable sails are all I need. I will need a main and a jib. Thank you very much

Mike Freshwater E-mail at: MLFRESH20@aol.com

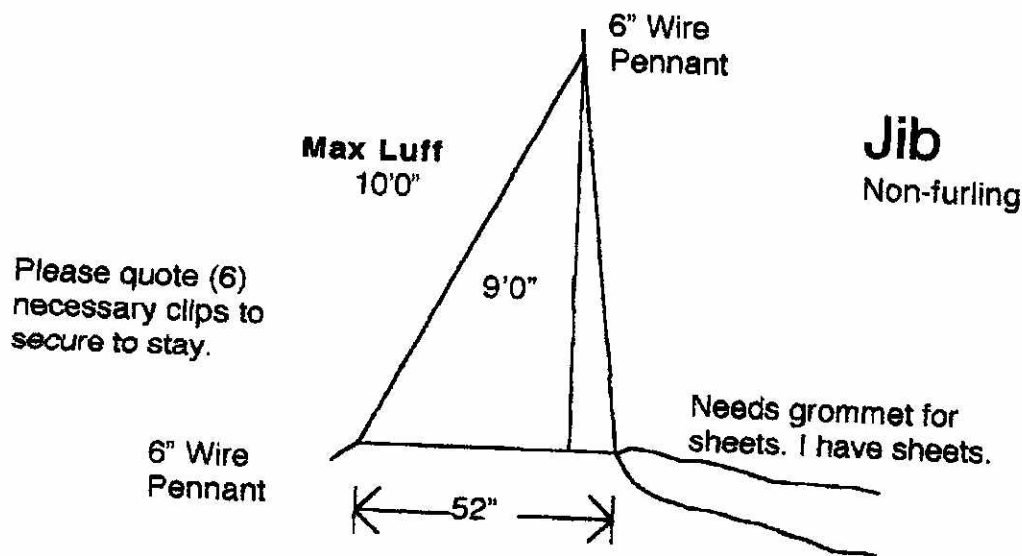
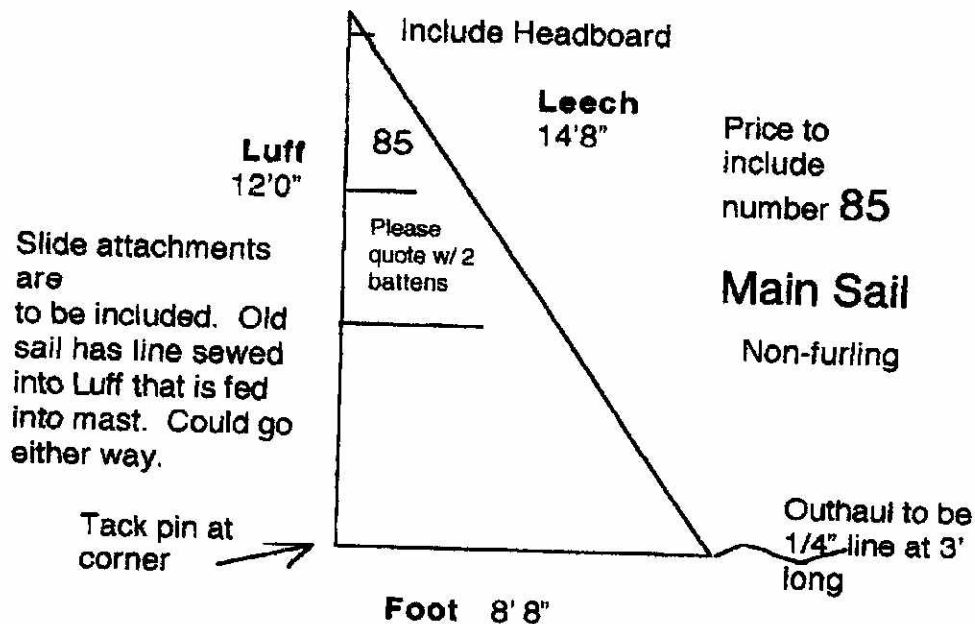

If you have any questions, please call me at (717) 951 - 1971. Please fax quote to (717) 898 - 4990. Quote is for estimate only. Firm pricing from low bidder after I send you my sails and give credit card #. Thank you

Mike Freshwater - Landisville, PA